

A cognitive perspective on the indirect framing of directive constructions

Guillaume DESAGULIER

gdesagulier@univ-paris8.fr

<http://www.univ-paris8.fr/desagulier/home>

Key concepts at issue

DIRECTIVES

Constructions by means of which S attempts to get H to do something

Tell the truth!

If I were you, I'd tell the truth

REQUESTS

Speech acts with a potential for social conflict

Face threatening acts
(Brown and Levinson)

Key concepts at issue

FACE

'an image of self delineated in terms of approved social attributes' (Goffman)

'the public self-image that every member wants to claim for himself' (B&L)

negative or positive
(cf handout)

FACEWORK

in verbal interaction, we tend to save, maintain or support each other's face

FTAs tend to be avoided (with notable exceptions) or mitigated

→ **INDIRECTNESS**

→ **POLITE BEHAVIOR**

Key concepts at issue

INDIRECTNESS

Leech

The Politeness Principle

- The cost-benefit scale
- The optionality scale
- The indirectness scale

B&L

5 superstrategies for FTAs

- Bald on record (-polite)
- Positive politeness
- Negative politeness
- Off record
- Withhold the FTA (+ polite)

Key concepts at issue

INDIRECTNESS

Blum-Kulka (1987, 1989, etc)

1. Mood derivable *Clean up after you!*
2. Performative *I'm asking you to clean up after you.*
3. Hedged performative *I would like to ask you to clean up after you.*
4. Obligation statement *You will have to clean up after you.*
5. Want statement *I want you to clean up after you.*
6. Suggestory formulae *How about cleaning up after you?*
7. Query preparatory *Would you mind cleaning up after you?*
8. Strong hints *You've left the room in a mess.*
9. Mild hints *We don't like finding the room in a mess.*

Key concepts at issue

WEIGHTINESS (B&L)

$$W_x = D(S, H) + P(H, S) + R_x$$

- $x = \text{FTA}$
- $D = \text{social distance between interlocutors}$
- $P = \text{relative power that H has over S}$
- $R = \text{rank (the degree of imposition of the FTA)}$

Indirectness = politeness?

IRONY

(1) *Would you think it an imposition on my part if I were to ask you not to answer your mobile phone in class?*

CASE WHERE POLITENESS IS IRRELEVANT

(2) *Don't make me come up to you and give you a spanky!*

Indirectness = politeness?

CULTURAL FACTORS

Blum-Kulka

- no cross-cultural linear correlation between non-conventional indirectness and politeness
- ex. 3 & 4

Problems with the classical approach

Much attention has been paid to

- (a) a characterization of indirect requests in terms of general, rigid speech acts or broadly defined cultural patterns
- (b) the correlation between indirectness (conventional or not) and politeness

Conversely, the cognitive roots of indirect requests and their realizations as linguistic constructions have received little attention

Problems with the classical approach

Linguists have thus left aside frequent situations in which the subtle form/meaning interplay made possible by some directive constructions echoes the ad hoc construction/negotiation of interactants' personhood.

This is particularly conspicuous when the specific role of each interactant is unclear or unconventional, and therefore subject to momentary negotiation.

Aims & Claims

Constructions – understood as conventional pairings of form and meaning – are themselves not just a question of linguistic form.

Their creation, use and modification are highly dependent on the creation/negotiation of personhood through verbal interaction.

Case study: pseudo directives

Occur when S attempts to get H to do something without giving the impression of restricting H's freedom of choice of action or without impinging upon H's self-assessment that s/he has that freedom of choice.

Constructions whose defining trait is not so much politeness (though it is not totally absent) as the ad hoc construction/negotiation of personhood.

Case study: pseudo directives

The pseudo-directive strategy in requests can be implemented either compressively or expansively.

Are the cognitive processes at work in each strategy radically different?

Compressive strategy

You want to X

(5) *You do not want to appear* brash or pushy. (*The Times*)

(6) *You might not want to take those drugs* if you drive.

(7) 'Did you enjoy that?'

'I did. Very much.'

'Really? Very much?'

'Yes.'

'But you hate the theatre.'

'I think ... I think I thought I hated the theatre. It was, it was a prejudice I hadn't examined properly.'

'You want to be careful.'

'Why?'

'If you start examining your prejudices carefully there'll soon be nothing left of you.'
(Nick Hornby, *How To Be Good*, 2001)

(8) *You wanna be careful* where you're throwing your accusations!

Compressive strategy

You want to X

- **Illocutionary act**

Speaker comments upon Hearer's objective need of doing X

- **Constructional pattern**

'Hearer wants X'

- **Illocutionary force**

Speaker wants Hearer to X

Deliberate vagueness (cognitive)

Ex.8 Apparently

S comments upon the objective necessity of being careful

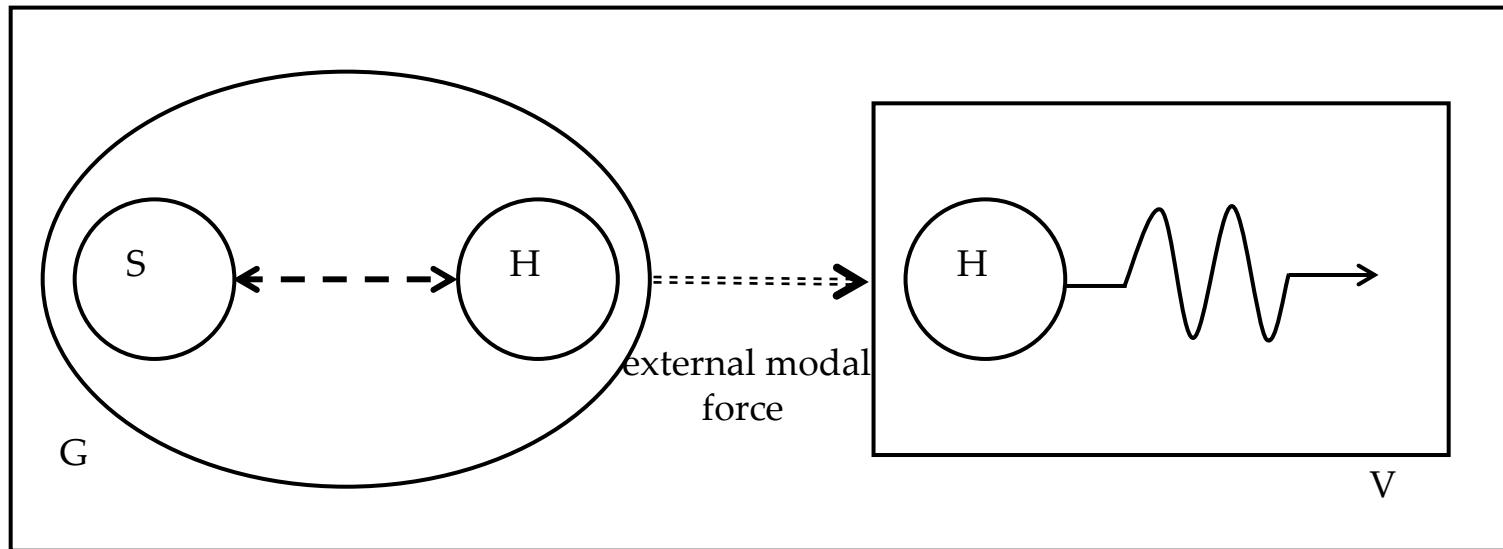

S speaker
H hearer
V virtual
G ground

Deliberate vagueness (cognitive)

In fact

S wants H to realize the process <be careful>

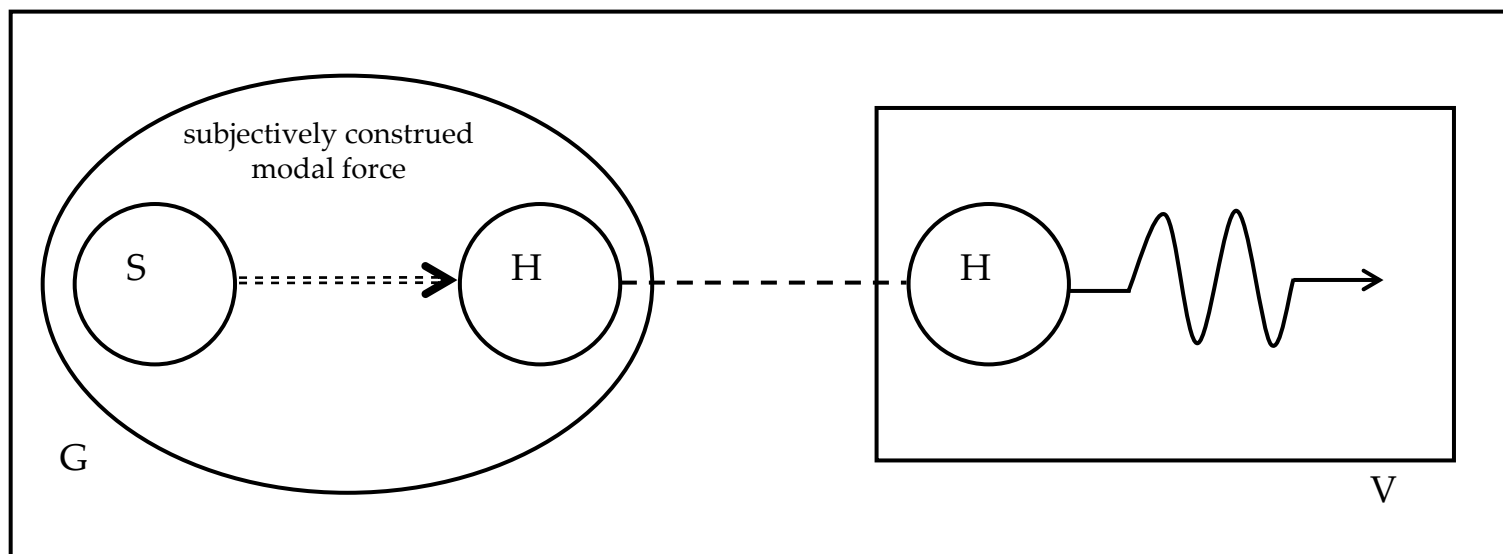

S speaker
H hearer
V virtual
G ground

Deliberate vagueness (cognitive)

Deliberate vagueness is particularly useful there is ad hoc negotiation regarding the role of each participant (politeness is not foregrounded)

S appears to put the cards in H's hand to avoid explicit coerciveness

does not put all the cards in H's hand for pragmatic clarity

H freedom from imposition \Rightarrow freedom of decision

nonetheless feels a certain pressure towards the realization of the process

S/H relieved of direct responsibility

collaborative work

can adjust, retract, or adapt to communicative development

Deliberate vagueness (constructional)

It is precisely the form/meaning compression typical of Fauconnier and Turner's grammatical blends that successfully frames the directive as collaborative work and mitigates the inherent coerciveness of the act.

Deliberate vagueness (constructional)

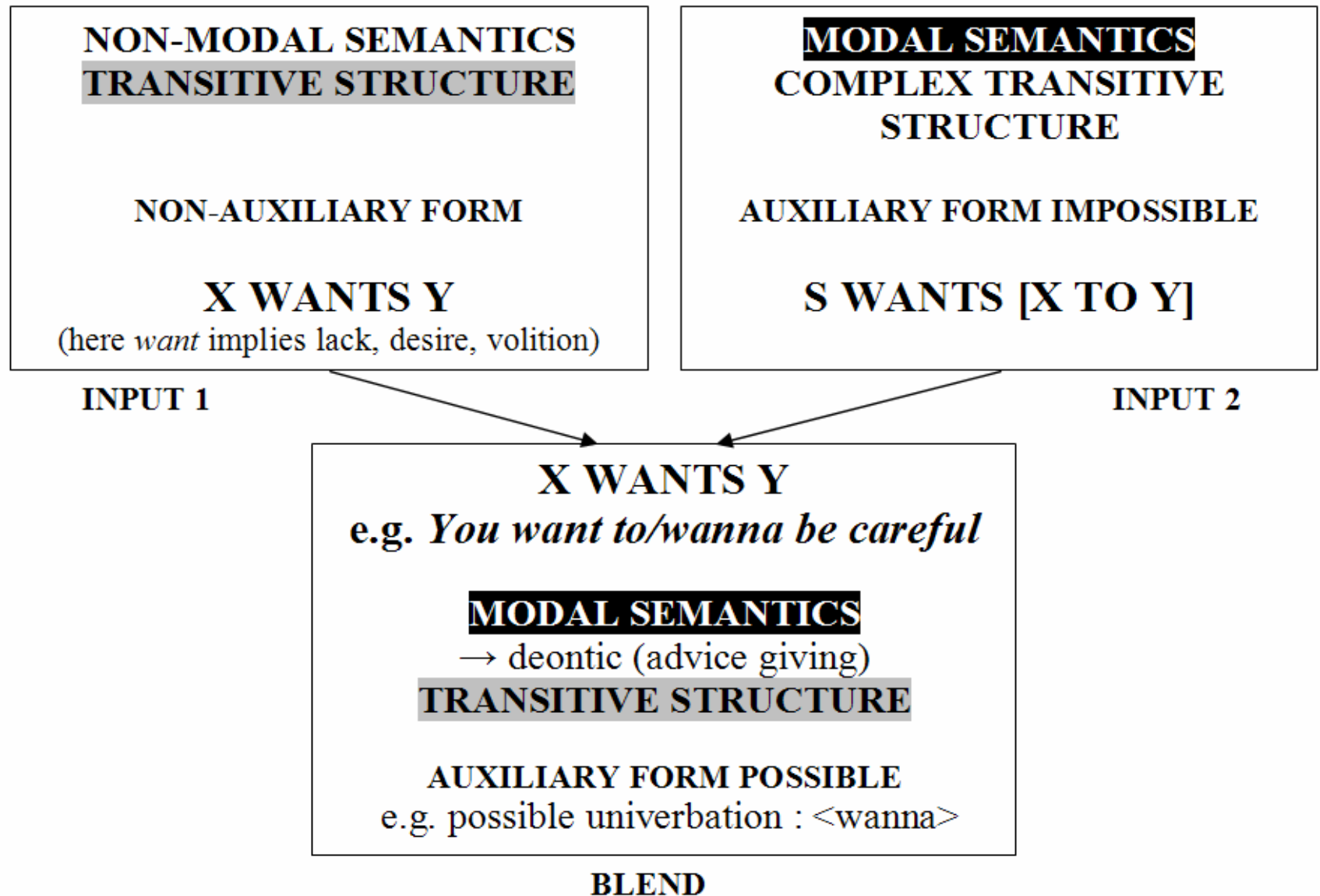

Expansive strategy

I am going to have to ask you to X

- (9) I told you again not to take any photographs. I'm going to have to ask you to stay behind.
- (10) I'm afraid I'm going to have to ask you to check with the Defense Department.
- (11) Mister, you can say anything you want about me, but I'm gonna have to ask you not to talk about my horse that way.
- (12) Police officer – I'm going to have to take your stick.
Cathy Berta - I know you're just doing your job.
[<http://www.progressive.org>]

Expansive strategy

I am going to have to ask you to X

The driving force of the illocutionary intent

Speaker wants Addressee to X

is realized as a Performative

'Speaker asks Addressee to X'

and disguised as something impending (*going to*)

and extrinsic from the speaker's own will (*have to*)

Improv Everywhere : Mission « Best Buy »

Improv Everywhere

<http://www.improveverywhere.com>

- A NYC-based improvization troupe formed in 2001
- Slogan : "We Cause Scenes"

Modus operandi

- pre-planned "missions" which usually involve socially awkward or unusual situations
- Goal: 'chaos and joy in public places'
- Ex : Synchronized Swimming in park fountain, taking the subway without pants, etc.

A reflection on emerging social phenomena cf. Hans Nickl, "in front of the Centre Pompidou"



Improv Everywhere : Mission « Best Buy »

In order to participate you must arrive adhering to a very specific dress code:

- 1) Blue Polo Shirt. Short sleeved. Any brand. Preferably with no logo. As Close to Royal Blue as possible.*
- 2) Khaki Pants. Any shade of khaki is fine. No shorts.*
- 3) Belt. Any belt is fine.*

Other Instructions:

- If possible, please wear black shoes. This is not required, but please wear them if you have them.*
- You must also bring a NEWSPAPER (Any newspaper is fine—just grab a free one on the street.)*
- If possible, do not bring a backpack or any type of bag. This is not a huge deal, but it will work better without bags.*
- Do not bring any type of camera. This mission is, as all IE Missions should be, participatory. We are covering it with our own small staff of camera people and do not need any more cameras or journalists. Only show up if you are wearing the proper dress and ready to participate and have fun!*

Improv Everywhere : Mission « Best Buy »



Improv Everywhere : Mission « Best Buy »



Conversation employee (E) / participant (P)



E- *I'm going to have to ask you to leave.*

P- *You're kicking me out?*

E- *No, I'm not saying that.*

P- *Ok, then I can stay? (...)*

E- *I'm asking you to leave.*

P- *Are you kicking me out?*

E- *No.*

Conversation employee (E) / participant (P)

E- *I'm going to have to ask you to leave.*

P- *You're kicking me out?*

E- *No, I'm not saying that.*

P- *Ok, then I can stay? (...)*

E- *I'm asking you to leave.*

P- *Are you kicking me out?*

E- *No.*

Moderate constraint E/P



Higher degree of constraint E/P

Indirect expansive strategy

Made necessary for legal reasons

Echoes the negotiation of mutual participant identities

<I'm going to have to ask you to X>

A semi-fixed idiomatic construction ("modular")

I am asking you to leave

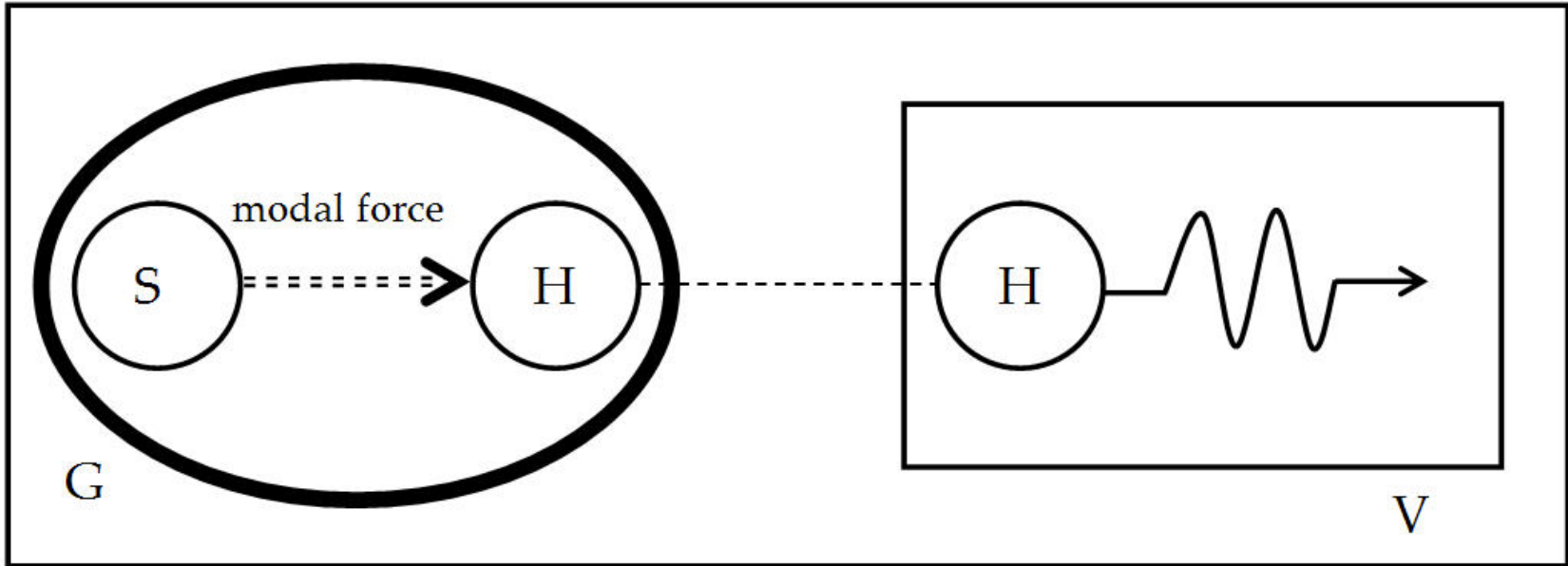

I am going to X

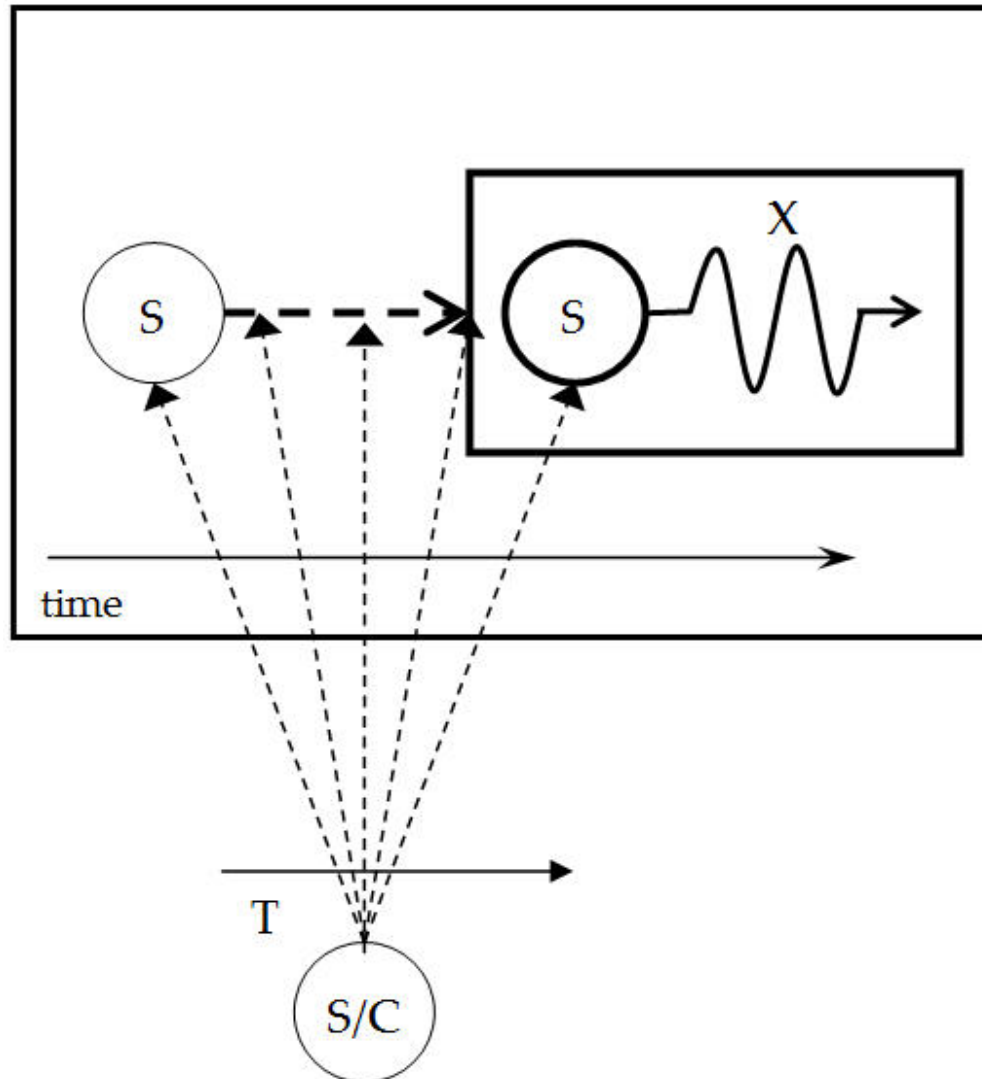

I have to X

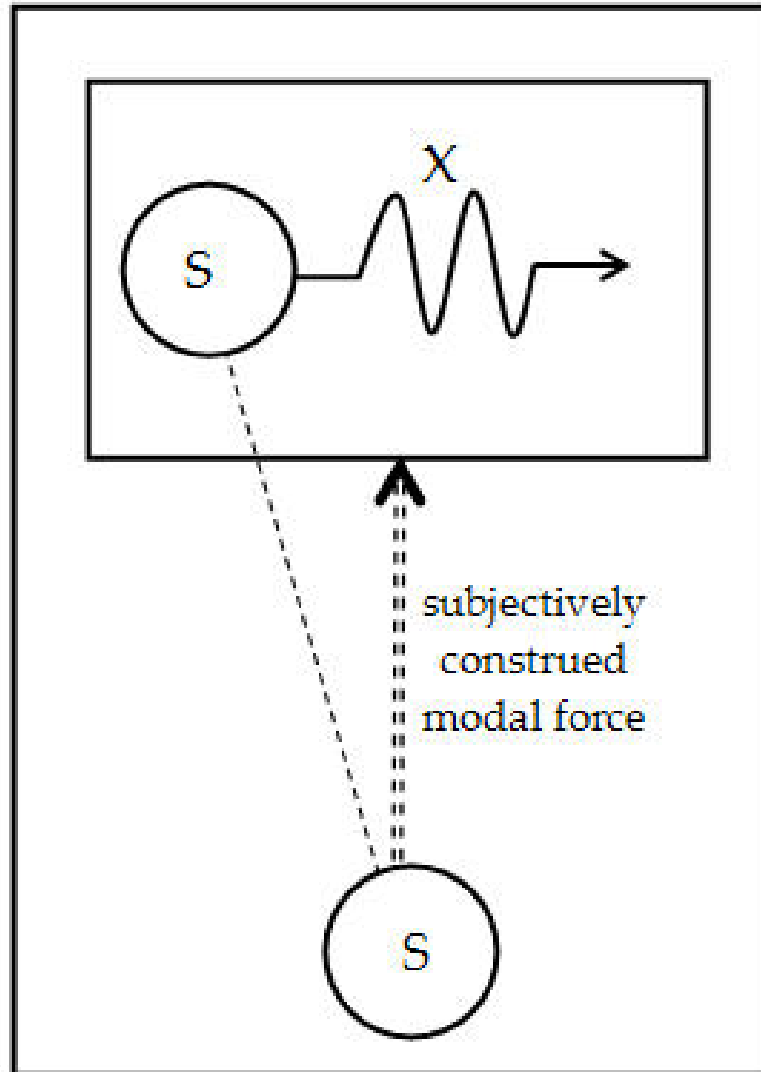

Cumulative hedging at the cognitive level

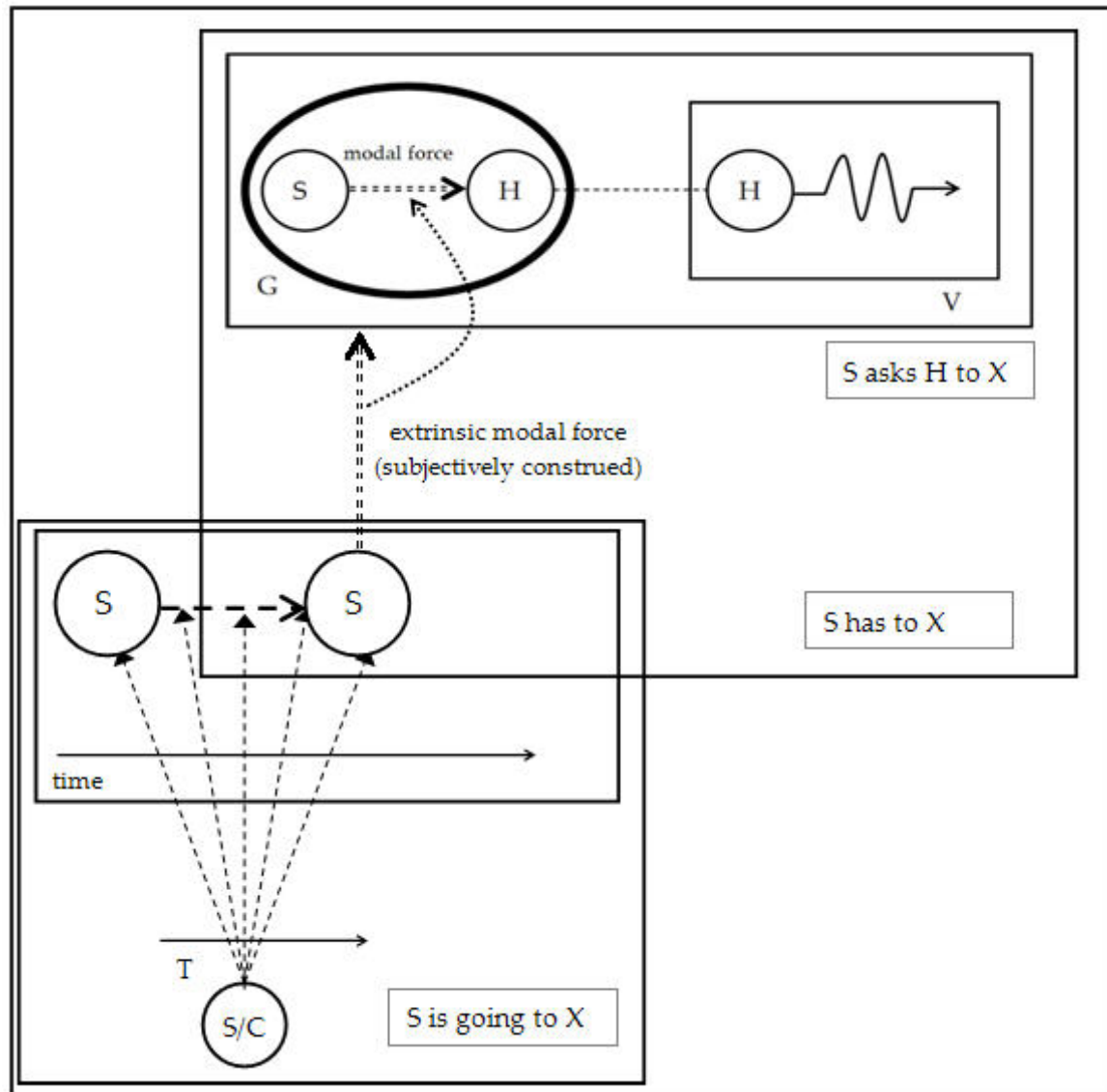

At the constructional level

EXPANSIVE STRATEGY

insofar as the catenative sequence marks iconic distance between S and the realization of the event. The more catenative elements S removes, the more constraining the request

COMPRESSIVE STRATEGY

since <I'm going to have to ask you to> forms a morphosyntactic chunk, i.e. an iconic marking of the cognitive conflation depicted above

Conclusion

- Deliberate vagueness is at work at two levels – cognitive and constructional – no matter which structural strategy – whether compressive or expansive – is adopted.
- The indirect framing of a directive construction is not just the property of an utterance limited to the sentence unit: it is constructed on the basis of a subtle combination of form and meaning at the crossroads of strict conventions and situation-specific variation.
- More importantly, grammatical constructions go hand in hand with the construction of personhood through verbal interaction.

Thanks for your attention !

<http://www.univ-paris8.fr/desagulier/home>